

"This Drawing Is Owned by J&V Science and Technology Co., Ltd., and the Use or Reproduction of All or Part of the Drawing Must Be Approved in Writing by J&V Science and Technology Co., Ltd."  
 此圖紙為劍威科技有限公司所擁有，所有或部份圖紙使用或复制必須經劍威科技有限公司書面同意。

版次 Version	A0	物料 编号 Drawing No	
客户代号 Customers		客户料号 Customers No	

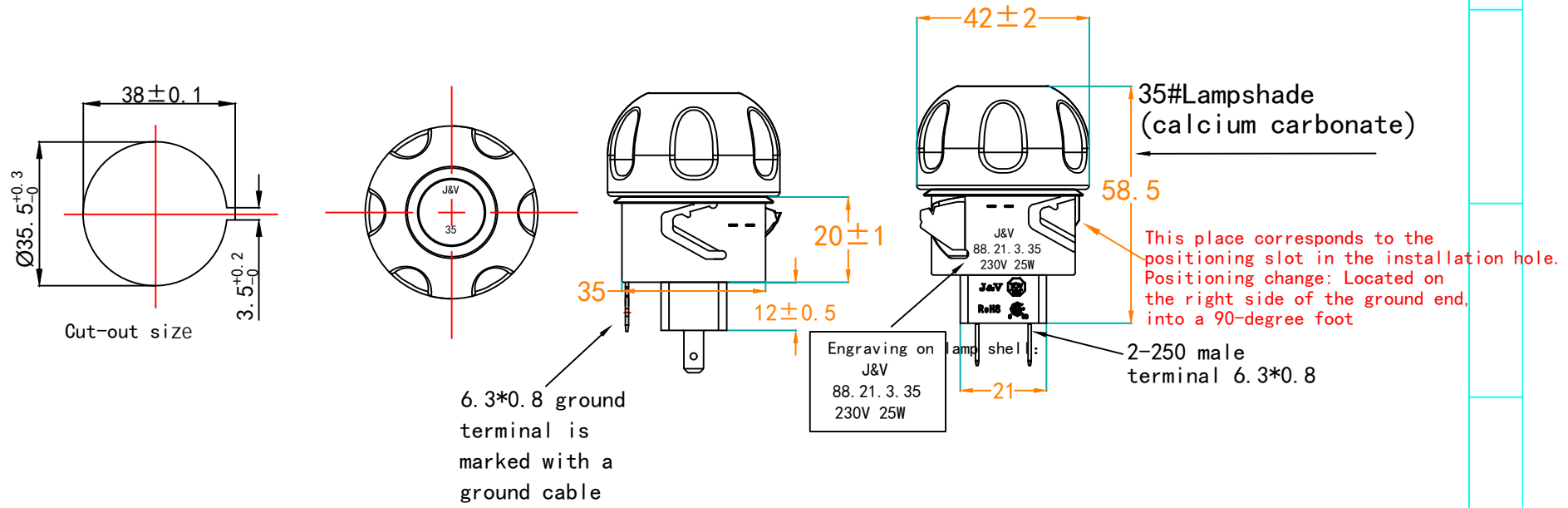

Technical requirements:

88.21.3.35

- Lamp holder ceramics: 88.21;
- Bulb: G9 230V 25W;
- Lampshade :35# lampshade (calcium carbonate);
- Terminal :250 straight insert  $6.3 \times 0.8$ ;
- Lamp shell material: SUS;
- Safety regulations: TUV, cURus, CQC, CE, SAA, ROHS.

产品 型号 Model No	刘凯	图纸 编号 Drawing No	88.21.3.35.92502	数量 Quantity	材质 Material
制图/日期 Drawing/Date	2023.02.23	规格 Specifications	G9 230V 25W	零件 名称 Parts Name	表面 处理 Surface Transaction
标记 Mark	更改前 Before Change	更改后 After Change	签名 Signature	日期 Date	
尺寸普通公差 Dimension Tolerance	$\pm 5$		投影 方向 Projection Direction	校对/日期 Collation/Date	 <b>J&amp;V</b> Science & Technology Co., Ltd 剑威科技
		角度 公差 Angle Tolerance	$\pm 1^\circ$	审核/日期 Verifying/Date	